

LIFT LUGS

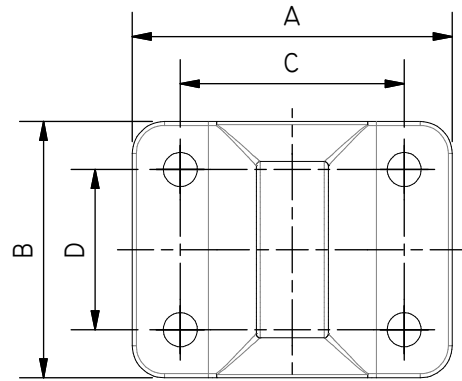

TOP

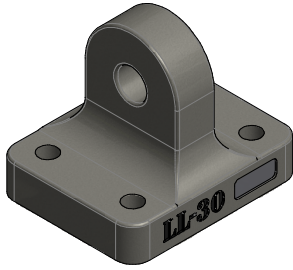
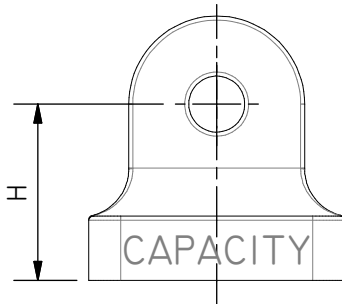

FRONT

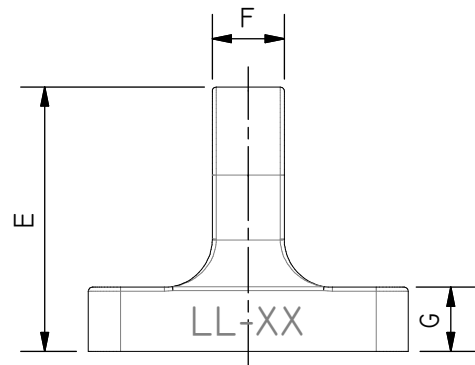

SIDE

LL-XX

- ° ALL MATERIALS, COMPONENTS AND WORKMANSHIP EXCEEDS THE CURRENT ASME B30.20.
- ° MADE TO ORDER ONLY. CALL FOR DELIVERY.

WORKING LOAD LIMIT	Stock No.	WEIGHT EACH (LBS.)	DIMENSIONS (IN.)								BOLT Ø (IN.)	SHACKLE HOLE Ø (IN.)
			A	B	C	D	E	F	G	H		
30T	LL-30	63.3	10.00	8.00	7.00	5.00	8.25	2.25	2.00	5.50	1.00	1.75
40T	LL-40	77.1	12.00	8.00	9.00	5.00	8.50	2.75	2.00	5.50	1.25	2.125
50T	LL-50	80.3	12.00	8.00	9.00	5.00	8.50	3.125	2.00	5.50	1.25	2.375
55T	LL-55	88.0	12.00	8.00	9.00	5.00	9.00	4.00	2.00	5.75	1.25	2.875

WORKING LOAD LIMIT	Stock No.	WEIGHT EACH (KGS.)	DIMENSIONS (MM)								BOLT Ø	SHACKLE HOLE Ø (IN.)
			A	B	C	D	E	F	G	H		
30T	LL-30	28.7	254.0	203.2	177.8	127.0	209.6	57.2	50.8	139.7	1.00 IN.	1.75
40T	LL-40	35.0	304.8	203.2	228.6	127.0	215.9	69.9	50.8	139.7	1.25 IN.	2.125
50T	LL-50M	36.4	304.8	203.2	228.6	127.0	215.9	79.4	50.8	139.7	30MM	2.375
55T	LL-55	40.0	304.8	203.2	228.6	127.0	228.6	101.6	50.8	146.1	1.25 IN.	2.875