

CAST LIFT BLOCKS

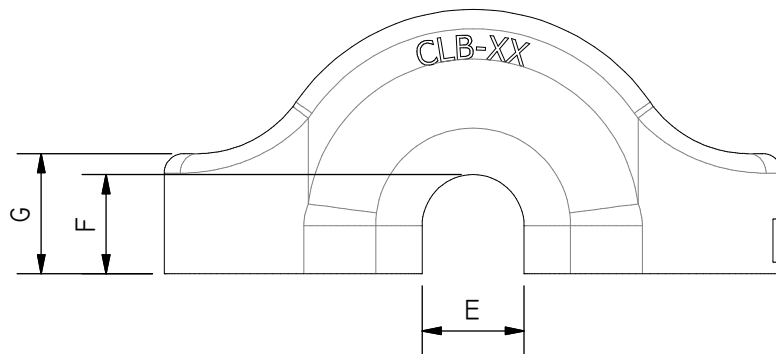
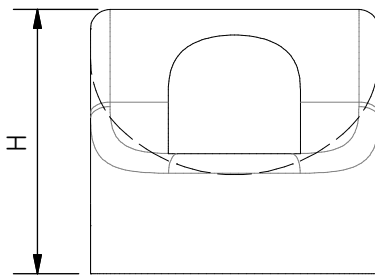
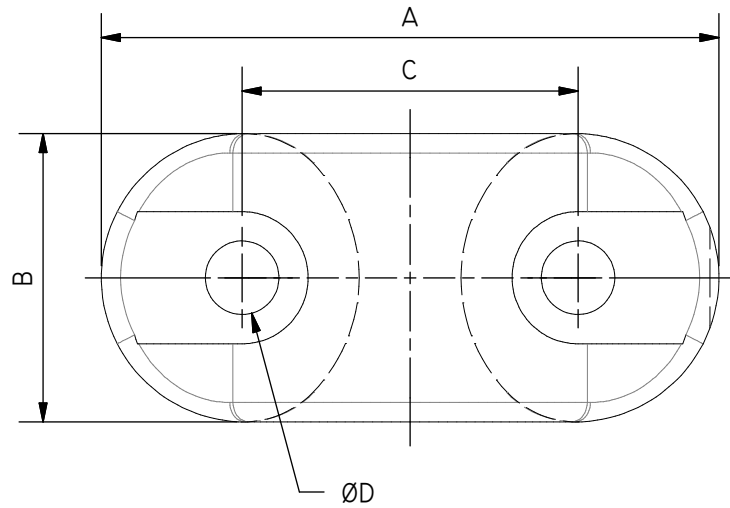
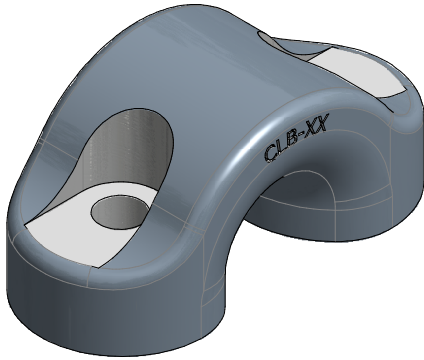

CLB-XX

ALL MATERIALS, COMPONENTS AND WORKMANSHIP EXCEEDS THE CURRENT ASME B30.20.

WORKING LOAD LIMIT (TONNE)	STOCK No.	WEIGHT EACH (LBS.)	DIMENSIONS (IN.)								BOLT Ø (MM.)
			A	B	C	D	E	F	G	H	
25	CLB-25	30.15	10.75	4.75	6.00	1.30	1.63	1.63	1.75	4.19	M30-3.5
50	CLB-50	61.22	12.87	6.00	7.00	1.77	2.13	2.06	2.50	5.50	M42-4.5

WORKING LOAD LIMIT (TONNE)	STOCK No.	WEIGHT EACH (KG.)	DIMENSIONS (MM.)								BOLT Ø (MM.)
			A	B	C	D	E	F	G	H	
25	CLB-25	13.7	273.1	120.7	152.4	33.0	41.2	41.2	44.5	106.4	M30-3.5
50	CLB-50	27.8	327.0	152.4	177.8	45.0	54.0	52.4	63.5	139.7	M42-4.5